

A FRAMEWORK FOR THE ANALYSIS OF DETERMINANTS OF SOCIAL MEDIA ACCEPTANCE IN HIGHER EDUCATIONAL INSTITUTES OF PAKISTAN

Ali Raza¹, Fida Hussain Chandio, M Yaqoob Koondhar, M Malook Rind, and Asadullah Shah²

¹Department of Computer Science, KICT, IIUM, alirazarang@gmail.com

²KICT, IIUM, chandiofida@gmail.com, Yaqoobkoondhar@gmail.com, engineermaalook@gmail.com, asadullah@iium.edu.my,

ABSTRACT. Social media is being considered an important source in the perspective of academic learning in the educational sector. The scope of learning through social media encompasses broadening the information sharing through collaborative approach with the help of web-based social networking sites as the means to enhance the knowledge of coworkers, colleagues and other mates. Due to large scale penetration of social media among youngsters, it is being perceived to be one of the futuristic approaches for next generation knowledge sharing and academic learning. On one hand, learning through social media has attained an important value in developed economies but on the other hand, real benefits and future implications have not been interpreted and realized in developing economies like Pakistan. Educational institutes in Pakistan need to evaluate and understand the importance and the usage of social networking for the sake of its valued role in academia. Although research communities in the developing countries are paying attention towards the development of this sector in academia but Pakistan still has to go a long way in this regard. The aim of the study is to explore the significant factors which are affecting the delayed acceptance and usage of social media for academic learning purpose. This research proposes an integrated framework including some widely accepted technology models such as Technology Acceptance Model (TAM) and Innovation Diffusion Theory (IDT) to determine significant factors.

Keywords: social media, learning, technology acceptance model and innovation diffusion theory

INTRODUCTION

Today's world has become a global village. In this world everything and everyone is interconnected through electronic devices which have diminished the barriers of communication. Today, social media have revolutionized the ways through which people living far and away from each other keep track of every single activity and movement of their friends and family. "Social media are a set of channels and technologies targeted at enabling and forming a potentially massive community of participants to productively collaborate. Social media has the six core features of collective, participative, independent, transparent, emergent and persistent that provides the unique value of social-media and, in combination, set social media apart from other forms of collaboration and communication" (Bradley, 2010).

This study is intended to focus on its current and future use of social media in the educational sector of Pakistan. An estimated 70% of the social media users in the country are people under the age of 25 years (The Express Tribune-30m internet users in Pakistan, half on mobile Report, 2013). This remarkable percentage shows that youngster of the country are involved in taking advantage of electronic means for sharing information. Social media can also be defined as applications and websites that allow users to develop or to participate or to share content through social networking. Social media networking sites such as Facebook, blogs, twitter (Junco, Heiberger, & Loken, 2011), LinkedIn, Graasp (Bogdanov, Limpens, El Helou, Salzmann, & Gillet, 2012), research gate, academia and other (HERI, 2007) offer hundreds of thousands of research notes and documents which provide incredible amounts of practical data and information for studies and trainings. The purpose of this study is to extend research on the social media acceptance among students in universities. An integrated framework of some widely used technology adoption and social theories including TAM and IDT are used to determine various significant factors of the social media. These theories will provide a way of critical understanding of the relations between different variables namely perceived ease of use, perceived usefulness, relevance, self-efficacy, compatibility and complexity. This is to diagnose the significant factors of social media acceptance for learning process.

RELATED WORK

TAM was presented to describe usage of computer behavior. TAM has remained the most frequently cited and important model or framework for understanding the information technology acceptance and has received extensive empirical support (Fred, Richard, Paul, 1989). TAM proposes two external variables as impact factors on two internal beliefs i.e. perceived utility and professed ease of use. PEOU is defined as degree to which using the new technology will be free of effort and PU is defined as degree to which a individual believes that using a specific system would improve her or his job or work performance (Davis, 1989). To study determinants of web based usage, different models are developed which were theoretical such as the unified theory of acceptance and use of technology, theory of planned behavior, theory of reasoned actions and technology acceptance model. TAM is generally adopted by researchers to investigate the determinant of usage and adoption of the technology such as social networking (Lim, Lim, & Heinrichs, 2008).

Diffusion of innovation has been generally useful in different disciplines such as marketing, sociology, education, agriculture, information technology, social media and communication (Rogers, Singhal, & Quinlan, 1995; Karahanna, & Chervany, 1999; Agarwal, Sambamurthy, & Stair, 2000). Innovation is defined as an object, idea or practice that is perceived as new by an individual and diffusion is defined as the process by which an innovation is communicated through certain channels over time among the members of a social system (Rogers et al., 1995). The IDT says that potential users make decisions to reject or adopt an innovation based on beliefs that they form about the innovation. Observables, trial ability, complexity, compatibility and relative advantage are five important characteristics of IDT.

PROPOSED CONCEPTUAL FRAMEWORK

Acceptance of Social Media

In this research the acceptance of social media for learning is a dependent variable, in this context the acceptance of social for learning refers to social media itself. Social media is the collection of communication networks devoted to collaboration, sharing and interaction. Applications and websites such as wikis, social bookmarks, social networks and micro blogs are various types of social media.

Perceived Usefulness

PU is defined as the degree to which an individual believes that using a specific system would improve his or her job performance (Davis, 1989). PU is level where student approach to predict their objective to use social media. Social media user interacts and is intrinsically motivated (Dhume, Pattanshetti, Kamble, & Prasad, 2012). PU suggests that students expected that by adopting new technology will improve their performance in their studies (Al-rahimi, Othman, & Musa, 2013). PU suggests that social media sites help every individual needs related to his goals. Applications and tools are offered to fulfill various types of services. It shows advantageous results by using attributes of technology (Ten Kate, Haverkamp, Mahmood, & Feldberg, 2010). PU defines the achievement of positive results by utilizing the social media and suggests that most important factor for teaching and learning with motivation is social media (Cao, Ajjan, & Hong, 2013). PU suggests that using various application, system and technology will improve performance. Those social networking sites which are easier to use and complexity is less are affective and are perceived more useful than those which are difficult to use. Social media builds confidence in user to share, create, get information and improve performance (Heinrichs, Lim, & Lim, 2011). Positive relationships in playing social networking games are also effective and have shown usefulness (E. Park, Baek, Ohm, & Chang, 2014). PU describe that mobile services provide connectivity anywhere through social networking (Gao, Ganapathy, Gopalakrishnan, & Gopalakrishnan, 2012). PU is the degree to which a user believes that using the social networking sites will improve his or her task outcome (Leng, Lada, Muhammad, Ibrahim, & Amboala, 2011). PU is to adopt new technology and to help individuals to achieve their needs or goals e.g. employment (Willis, 2008). PU suggests that social networking users are growing as it facilitates the communication between members of communities. It provides useful activities according to users demand (Kwon & Wen, 2010).

H1: PU will have a significant positive effect on acceptance of social media.

Perceived Ease of Use

PEOU defines as the degree to which using the technology will be free of effort (Davis, 1989). PEOU is the belief in one's ability to execute and organize actions which required situation to manage. Social networking sites are designed such that it's easy for anyone to use. Search engine designs are truly cool too. Students develop better understanding and show results in e-learning (Dhume, Pattanshetti, Kamble, & Prasad, 2012). PEOU suggests that student expect that by adopting new technology will improve their performance in their studies. Individuals believe that it will be free of cognitive effort and will offer ease of use (Al-rahimi, Othman, & Musa, 2013). PEOU suggests that social networking sites should be easy to use so that user can achieve desired objectives without wasting time on understanding how to operate it. It should encourage the user to share and create new innovations (Heinrichs, Lim, & Lim, 2011). Libraries need to be easy to use and learn to avoid inconvenience (Hong, Thong, James, Wong, & Tam, 2002). PEOU describes the usefulness of mobile devices and suggests that these must be easy to operate and understand (Park, Baek, Ohm, & Chang, 2014). PEOU focuses on the advantages of mobile phones being used in social networking especially for business purposes. The most advantageous aspect of social networking through mobile phone is that one can use business application anywhere without any difficulty (Gao, et al. 2012). PEOU describes the key role of social networking sites i.e. to build relations among students (Leng, Lada, Muhammad, Ibrahim, & Amboala, 2011). PEOU suggests that social networking systems that are easy to use are much more useful than those which are difficult to use (Willis, 2008). PEOU describes how technology has influenced people's lives through social networking (Kwon & Wen, 2010).

H2a: PEOU will have a significant positive effect on acceptance of social media.

H2b: PEOU will have a significant positive effect on PU of acceptance of social media.

Compatibility

Compatibility is extent of individual previous experience of technology and has a positive association with new information technology acceptance (Agarwal & Prasad, 1999). Compatibility is found to be important in relation to perceived usefulness with its effect. Compatibility may affect perceived usefulness or perceived ease of use and indirectly influence behavioral intention of the user. Users recognize the compatibility of technology considering their work requirement (Chau & HU, 2002). Compatibility has direct and positive effect on behavioral intention and perceived usefulness (Kwon, Park, & Kim, 2014; Chang & Tung, 2007). Previous studies show that compatibility impacts professed usefulness, perceived easiness of use and intention for use (Hardgrave, Davis, & Riemenschneider, 2003). The diffusion of innovation suggests that compatibility of social media applications and tools are for quality education by the faculty members (Rogers, Singhal, & Quinlan, 1995; Cao, Ajjan, & Hong, 2013).

H5a: Compatibility will have a significant positive effect on PU of acceptance of social media.

H5b: Compatibility will have a significant positive effect on PEOU of acceptance of social media.

Complexity

Previous studies have shown that the complexity has very major negative effect on perceived usefulness and intention for use (Hardgrave, Davis, & Riemenschneider, 2003). Research shows that the more it is complex for end user to perceive social networking or e-learning system, the lower end user intends to use the system (Pituch & Lee, 2006).

H6a: Complexity will have a significant negative effect on PU of acceptance of social media.

H6b: Complexity will have a significant negative effect on PEOU of acceptance of social media.

Relevance

Relevance is the degree in which the system matches tasks as accepted out in the current environment and as identified in the task analysis. Relevance takes into account both recall and precision so that effectiveness of retrieval information system are measured (Su, 1994). Relevance is concept which plays the key role to evaluate the effectiveness of retrieval information system for user based judgments. In fact, evaluation of information retrieval systems revolves around the idea of relevance (Park, 1994; Spink, Greisdorf, & Bateman, 1998). Relevance is resolving information needs by retrieving items for user satisfaction. Satisfaction and relevance has a strong relationship (Gluck, 1996). Relevance is related to user considering data or documents which are useful according to the requirement (Yao, 1995). Subsequently, if a social media has relevant information available on a large scale then it will be easier for the user to retrieve useful information.

H3a: Relevance will have a significant positive effect on PU of acceptance of social media.

H3b: Relevance will have a significant positive effect on PEOU of acceptance of social media.

Self-efficacy

Self-efficacy belief defines people’s judgments of their willingness to achieve a certain level of performance. Judgment of self-efficacy usually determines the effort someone will put in and how long that effort will persist (Bandura, 1986). Conceptualize self-efficacy is the domain of social media self-efficacy or an individual’s belief about her or his capabilities to do desired functions specifically in the social media environment. We apply social media self-efficacy to examine the degree to which people vary in their evaluations of the trustworthiness of online information relative to offline information (Bandura, 1977; Bandura, 1994). Self-efficacy is student’s degree of confidence that they can successfully use social media in the classroom (Greenhow, 2008). Self-efficacy is an individual believes that one is able to do a specific task with the use of social media (Eastin & LaRose, 2006). Self-efficacy is self-confidence to do work such as communication, research and creativeness with the use of social media (Mungania & Reio.Jr, 2005). Self-efficacy is an antecedent of perceived ease of use (Jong & Wang, 2009).

H4a: Self-efficacy will have a significant positive effect on PU of acceptance of social media.

H4b: Self-efficacy will have a significant positive effect on PEOU of acceptance of social media.

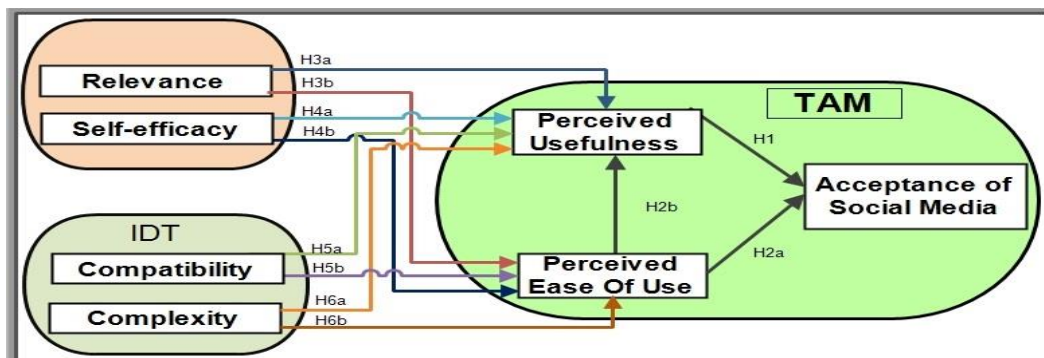

Figure 1. Proposed Research Model for Acceptance of Social Media

CONCLUSION

Social media can be effective for both students and teachers and it provides opportunity to educate and motivate students through new tools and techniques. Social media are beneficial for student learning in multiple ways such as interaction with the teacher, communication with other students and sharing the data and materials. Future work will be fully based on survey of different universities for the use of social media by students of various institutes for collaboration and sharing knowledge. With the use of social media, students develop critical thinking and know about modern knowledge related to studies. Teachers can create a better educational environment between students and with other faculty members by using social media and can increase their learning skills using advance media based teaching techniques.

REFERENCES

- Agarwal, R., & Prasad, J. (1999). Are Individual Differences Germane to the Acceptance of New Information Technologies? *Decision Sciences*, 30(2), 361–391.
- Agarwal, R., Sambamurthy, V., & Stair, R. M. (2000). The evolving relationship between general and specific computer efficacy. *Information Systems Research*, 11(4), 418-30.

- Al-rahimi, W. M., Othman, M. S., & Musa, M. A. (2013). Using TAM Model To Measure The Use Of Social Media For Collaborative Learning, *International Journal of Engineering Trends and Technology (IJETT)*, 5, 90–95.
- Bandura, A. (1977). Self-efficacy: Toward a unifying theory of behavioral change. *Psychological Review*.
- Bandura, A. (1986). *Social Foundations of Thought and Action : A Social-Cognitive View*, Prentice Hall:Englewood Cliffs, NJ, (pp. 5–107)
- Bandura, A. (1994). *Self-Efficacy* (Vol. 4, pp. 71–81). John Wiley & Sons, Inc..
- Bogdanov, E., Limpens, F., Li, N., El Helou, S., Salzmann, C., & Gillet, D. (2012). A social media platform in higher education. In *Global Engineering Education Conference (EDUCON)* , 1–8. IEEE.
- Bradley, A. J. (2010). A New Definition of Social Media. Retrieved October 19, 2014, from http://blogs.gartner.com/anthony_bradley/2010/01/07/a-new-definition-ofsocial-
- Cao, Y., Ajjan, H., & Hong, P. (2013). Using social media applications for educational outcomes in college teaching: A structural equation analysis. *British Journal of Educational Technology*, 44(4), 581–593.
- Chang, S.-C., & Tung, F.-C. (2007). An empirical investigation of students' behavioural intentions to use the online learning course websites. *British Journal of Educational Technology*, 39(1), 070625111823003
- Chau, P. Y. ., & HU, P. J. (2002). Examining a Model of Information Technology Acceptance by Individual Professionals : An Exploratory Study. *Journal of Management Information Systems*, 2(4), 191–229.
- Davis, F. D. (1989). Perceived usefulness, Perceived ease of use and User acceptance of information technology. *MIS Quarterly*, 13(3), 319–340.
- Dhume, S. M., Pattanshetti, M. Y., Kamble, S. S., & Prasad, T. (2012). Adoption of social media by Business Education students: Application of Technology Acceptance Model (TAM). In *2012 IEEE International Conference on Technology Enhanced Education (ICTEE)*, 1–10.
- Eastin, M. S., & LaRose, R. (2006). Internet Self-Efficacy and the Psychology of the Digital Divide. *Journal of Computer-Mediated Communication*, 6(1), 0–0.
- Fred D. Davis, Richard P. Bagozzi, Paul R. Warshaw. (1989). User Acceptance Of Computer Technology: A Comparison of Two Models. *Management Science*.
- Gao, S., Ganapathy, R., Gopalakrishnan, V., & Gopalakrishnan, S. (2012). An exploratory study on the adoption of mobile services through social media. In *2012 International Conference on Systems and Informatics (ICSAI2012)* (pp. 2588–2592).
- Gluck, M. (1996). Exploring The Relationship Between User Satisfaction And Relevance In Information System. *Information Processing & Management*, 32(1), 89–104.
- Greenhow, C. (2008). Connecting Informal and Formal Learning Experiences in the Age of Participatory Media. *Contemporary Issues in Technology and Teacher Education*, 8(3), 187–194.
- Hardgrave, B., Davis, F. D., & Riemenschneider, C. K. (2003). Investigating Determinants of Software Developers' Intentions to Follow Methodologies. *Journal of Management Information Systems*, 20(1), 123–151.

- Heinrichs, J. H., Lim, J., & Lim, K. (2011). Influence of social networking site and user access method on social media evaluation. *Journal of Consumer Behaviour*, 10(6), 347–355.
- HERI. (2007). *College Freshmen and Online Social Networking Sites* (pp. 1–3). Los Angeles.
- Hong, W., Thong, James Y. L., Wong, W., & Tam, K. (2002). Determinants of User Acceptance of Digital Libraries: An Empirical Examination of Individual Differences and System Characteristics. *Journal of Management Information Systems*, 18(3), 97–124.
- Jong, D., & Wang, T. S. (2009). Student Acceptance of Web-based Learning System. In *proceedings of the 2009 International Symposium on Web Information System and Application (WISA'09) Nanchang, P.R.China*, 533–53. Prentice Hall.
- Junco, R., Heiberger, G., & Loken, E. (2011). The effect of Twitter on college student engagement and grades. *Journal of Computer Assisted Learning*, 27(2), 119–132.
- Karahanna, E., Straub, D., & Chervany, N. (1999). Information technology adoption across time: A cross-sectional comparison of Pre adoption and Post adoption beliefs. *MIS Quarterly*, 23(2), 183–213.
- Kwon, O., & Wen, Y. (2010). An empirical study of the factors affecting social network service use. *Computers in Human Behavior*, 26(2), 254–263.
- Kwon, S. J., Park, E., & Kim, K. J. (2014). What drives successful social networking services? A comparative analysis of user acceptance of Facebook and Twitter. *The Social Science Journal*, 1–11.
- Leng, G. S., Lada, S., Muhammad, M. Z., Ibrahim, A. A. H. A., & Amboala, T. (2011). An exploration of social networking sites SNS adoption in Malaysia using Technology Acceptance Model TAM, Theory of Planned Behavior TPB and Intrinsic Motivation. *Journal of Internet Banking and Commerce*, 16(2), 1–27.
- Lim, K.-S., Lim, J.-S., & Heinrichs, J. H. (2008). Testing an Integrated Model of E-Shopping Web Site Usage. *Journal of Internet Commerce*, 7(3), 291–312.
- Mungania, P., & Reio, Jr., T. G. (2005). If E-learners Get There, Will They Stay? The Role of E-learning Self-Efficacy. *Online Submission*, 1110–1117.
- Park, E., Baek, S., Ohm, J., & Chang, H. J. (2014). Determinants of player acceptance of mobile social network games: An application of extended technology acceptance model. *Telematics and Informatics*, 31(1), 3–15.
- Park, T. K. (1994). Toward a Theory of User-Based Relevance: A Call for a New Paradigm of Inquiry. *Journal of the American Society for Information Science*, 45(3), 135–141.
- Pituch, K. a., & Lee, Y. (2006). The influence of system characteristics on e-learning use. *Computers & Education*, 47(2), 222–244.
- Rauniar, R., Rawski, G., Yang, J., & Johnson, B. (2014). Technology acceptance model (TAM) and social media usage: an empirical study on Facebook. *Journal of Enterprise Information Management*, 27(1), 6–30.
- Rogers, E. M., Singhal, A., & Quinlan, M. M. (1995). *Diffusion of Innovations* Everett M. Rogers, 1–25. New York.
- Spink, A., Greisdorf, H., & Bateman, J. (1998). From highly relevant to not relevant: Examining different regions of relevance. *Information Processing & Management*, 34(5), 599–622.

- Su, L. T. (1994). The relevance of recall and precision in user evaluation. *Journal of the American Society for Information Science*, 45(3), 207–217.
- Ten Kate, S., Haverkamp, S., Mahmood, F., & Feldberg, F. (2010). Social network influences on technology acceptance : A matter of tie strength , centrality and density, 18–32.
- The Express Tribune-30m internet users in Pakistan, half on mobile Report. (2013). Retrieved October 01, 2014, from <http://tribune.com.pk/story/567649/30m-internet-users-in-pakistan-half-on-mobile-report/>
- Willis, T. J. (2008). *An evaluation of the Technology Acceptance Model as a means of understanding online social networking behavior*. ProQuest.
- Yao, Y. Y. (1995). Measuring Retrieval Effectiveness Based on User Preference of Documents. *JASIS*, 46(2), 133–145.